

WIPO/PCT Patents Fulltext

FILE DESCRIPTION

The **WIPO/PCT Patents Fulltext** database covers the full text of PCT (Patent Cooperation Treaty) published applications issued under the auspices of the World Intellectual Property Organization (WIPO) since 1978. At present, 177 member states participate in the PCT system. A single PCT application can be designated as valid in any or all of the member states, so it is essentially equivalent to having filed with each designated national and regional patent office.

The **WIPO/PCT Patents Fulltext** database is produced by Thomson Scientific and WIPO. WIPO bibliographic data is available online within 1-2 days of publication. Full text data provided by Thomson Scientific is searchable online approximately 5-7 days after publication of the document. Original WIPO patent documents are converted into electronic form through an optical scanning (OCR) process. The OCR process is a reliable method of converting documents into electronic form, however occasional characters may be converted incorrectly.

Records in the database contain the searchable text of the complete document, including the specification and claims; titles and abstracts in French and English; patent applicant/assignees and inventors; and patent and priority application data. The majority of fulltext documents are in English. Documents are also available in French, German and Spanish. Text originally provided to WIPO in non-Latin characters, i.e., Greek, Chinese, etc. is not included due to the difficulty of scanning and accurately converting non-Latin characters.

Patent and application numbers are standardized on the Dialog service, so they can easily be searched in other patent databases. The MAP command can be used to capture WO published application numbers (prefix PN=) or priority application numbers (prefix AN=) in File 349. The resulting saved strategy can then be executed in another file using the EXS command to obtain additional information about the original invention. For example, File 345, Inpadoc, contains legal status actions pertaining to PCT (WO) patents and patent family information. PCT data is also referenced in U.S. Patents Fulltext (Files 652-654); CLAIMS®/U.S. Patents (File 340); and in European Patents Fulltext (File 348).

SUBJECT COVERAGE

All areas of patentable technology are included.

TIPS

USE FILE 349

to search the fulltext of PCT patents.

USE AN=

to monitor priority applications of PCT patents.

S AN=SE 992435

USE RANK

for statistical analysis of data fields such as assignee.

SELECT TOPIC; RANK PA

USE MAP

to save patent numbers for the purpose of locating additional information such as legal status, in other files

SELECT TOPIC; MAP PN TEMP

CREATE AN ALERT

to monitor new PCT documents for a particular technology or competitor.

DIALOG FILE DATA

Inclusive Dates: 1978+

Update Frequency: Weekly

File Size: 1,155,000 records as of September 2006

CONTACT

The WIPO/PCT Database is produced by Thomson Scientific. Questions about database content should be directed to:

Dialog LLC
Knowledge Center
2250 Perimeter Park Drive
Suite 300

Morrisville, NC 27560

Phone: 919.804.6400
Toll Free: 1-800-3DIALOG
Fax: 919.804.6410
E-Mail: customer@dialog.com

DIALOG(R)File 349:PCT FULLTEXT 1979-2006/UB=20060817,UT=20060810
(c)2006 WIPO/Thomson Corp. All rts. reserv.

00811080 **Image available**

/TI
/TF

AN ANCHOR BOLT ASSEMBLY
SYSTEME DE BOULON D'ANCRAGE

PA=, /CO, CO=
GL=, CN=

Patent Applicant/Assignee:
RSC MINING (PROPRIETARY) LIMITED, 30 Industry Road, Clayville Ext. 4,
Olifantsfontein, 1666 Midrand, ZA, ZA (Residence), ZA (Nationality),
(For all designated states except: US)

AU=, PA=

Patent Applicant/Inventor:
DEKKER Arie Cornelis, 15 Bateleur Bastion, 969 Disselboom Avenue, 0050
Wapadrand, ZA, ZA (Residence), ZA (Nationality), (Designated only for:
US)

LR=

Legal Representative:
VIVIER Garth (agent), Adams & Adams, P.O. Box 1014, 1140 Prospect Street,
Hatfield, 0001 Pretoria, ZA,

Patent and Priority Information (Country, Number, Date):

PC=, PN=, PD=, PY=
AC=, AN=, AD=, AM=, AY=
AC=, AN=, AD=, AM=, AY=
DS=

Patent: WO 200144621 A1 20010621 (WO 0144621)
Application: WO 2000IB1789 20001204 (PCT/WO IB0001789)
Priority Application: ZA 997711 19991215

Designated States:

(Protection type is "patent" unless otherwise stated - for applications
prior to 2004)

AE AG AL AM AT AU AZ BA BB BG BR BY BZ CA CH CN CR CU CZ DE DK DM DZ EE
ES FI GB GD GE GH GM HR HU ID IL IN IS JP KE KG KP KR KZ LC LK LR LS LT
LU LV MA MD MG MK MN MW MX MZ NO NZ PL PT RO RU SD SE SG SI SK SL TJ TM
TR TT TZ UA UG US UZ VN YU ZA ZW
(EP) AT BE CH CY DE DK ES FI FR GB GR IE IT LU MC NL PT SE TR
((OAPI utility model)) BF BJ CF CG CI CM GA GN GW ML MR NE SN TD TG
(AP) GH GM KE LS MW MZ SD SL SZ TZ UG ZW
(EA) AM AZ BY KG KZ MD RU TJ TM

IC=
LA=
LF=
WD=

Main International Patent Class: E21D-021/00
Publication Language: English
Filing Language: English
Fulltext Word Count: 3641

/AB, /AE

English Abstract

An anchor bolt is provided including an elongate anchor element which includes a threaded portion and a ribbed portion. The ribbed portion has an elongate cylindrical core on which a plurality of spaced ribs are provided, at least two adjacent ribs being of different height relative to the core. In certain embodiments, the ribs are curved in a serpentine fashion relative to a peripheral surface of the core. The core is typically a circular cylindrical core and the ribbed portion may include two longitudinal raised portions which extend along the cylindrical core at circumferentially opposed positions. The raised portions define core sections, each core section including a plurality of spaced ribs which alternate in height, adjacent ribs being about 1 mm and 0.6 mm in height. Typically, the ribs have a rounded profile with a radius of curvature of about 0.5 mm.

/AB, /AF

French Abstract

La presente invention concerne un boulon d'ancrage comprenant un element d'ancrage allonge presentant une partie filetee et une partie cannelee. La partie cannelee presente un element central cylindrique allonge sur (...)

LD=, LS=, LT= /LS

Legal Status (Type, Date, Text)

Publication 20010621 A1 With international search report.

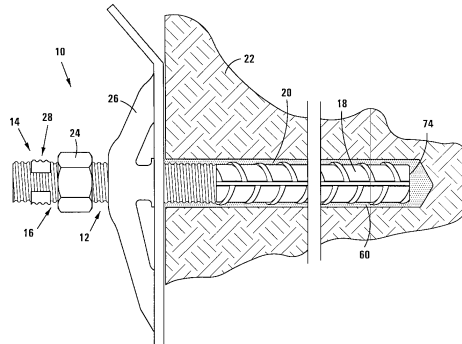

SAMPLE RECORD (cont'd)

/SP,/TX

Detailed Description

AN ANCHOR BOLT ASSEMBLY

THIS INVENTION relates to an anchor assembly. It also relates to an anchor bolt for use with an anchor assembly and to an elongate bar.

For the purposes of this specification, the application of the invention in mining operations should be predominately, but not exclusively, borne in mind. Accordingly, the anchor assembly may be used as a rock anchor e.g. a roof bolt or the like.

According to the invention there is provided an anchor bolt assembly which includes an elongate anchor element including a threaded portion and a ribbed portion, the ribbed portion including an elongate cylindrical core on which a plurality of spaced ribs are provided, at least two adjacent ribs being of different height; and a bearing arrangement which includes a screw-threaded nut which is received on the threaded portion of the anchor element. Typically, the assembly includes a dome washer with a dogear.

(...)

/CM,/TX

Claim

1 An anchor bolt including an elongate anchor element, which includes a threaded portion and a ribbed portion, the ribbed portion including an elongate cylindrical core on which a plurality of spaced ribs are provided, at least two adjacent ribs being of different height relative to the core.

2 An anchor bolt as claimed in Claim 1, in which the ribs are curved in a serpentine fashion relative to a peripheral surface of the core.

3 An anchor bolt as claimed in Claim 1 or Claim 2, in which the ribbed portion includes two longitudinal raised portions which extend along the cylindrical core at circumferentially opposed positions.

(...)

SEARCH OPTIONS

BASIC INDEX

SEARCH SUFFIX	DISPLAY CODE	FIELD NAME	INDEXING	SELECT EXAMPLES
—	—	All Basic Index Fields ^{1,2}	Segment & Word	S DI(W)CHLORO S ANCHOR(5N)ASSEMBLY
/AB	AB	Abstract ^{1,2}	Segment & Word	S CHLORO(T)ACETIC/AB S EQUALIZER(W)WHEEL?/AB
/AE	AE	English Abstract ^{1,2}	Segment & Word	S CHLORO(W)ACETIC/AE S OPTICAL(W)(FIBER? OR FIBRE?)/AE
/AF	AF	French Abstract ^{1,2}	Segment & Word	S CARBONYLE/AF S FIBRES(N)OPTIQUES/AF
/AG	AG	German Abstract ²	Segment & Word	S DI(W)CHLOR? S GALVANISCHE(W)KUPERAB?/AG
/CM	CM	Claims ^{2,4}	Segment & Word & Word	S DI(W)CHLORIDE/CM S DISPLACEMENT(W)CONNECTOR?/CM S DI(W)CHLORIDE/CM S ANCHOR(W)BOLT/CM
/CO	CO	Company (Assignee/Applicant) ^{1,3}	Word	S RSC/CO
/LS	LS	Legal Status Text	Word	
/SP	SP	Specification ^{1,2,4}	Segment & Word & Word	S ETHYLENE(W)CHLORIDE/SP S PROTECTIVE (W) STRUCTURE/SP S ETHYLENE(W)CHLORIDE/SP S CONNECTOR(W)TERMINAL?/SP
—	TE	Title in English		
—	TF	Title in French		
—	TG	Title in German		
/TI	TI	Title ^{1,2}	Segment & Word	S BOLT(W)ASSEMBLY/TI S BOULON(1W)ANCRAGE/TI
—	TS	Title in Spanish		
/TX	TX	All Text ^{1,2,4}	Segment & Word	S EXTRUDED(5N)STEEL/TX S (LOGITUDINAL(S)CORETX

¹ Text fields have been created by means of optical scanning of printed text. Therefore, some terms may be misspelled, or portions of text may be incomplete if the scanner was unable to identify characters correctly.

² All chemical names are indexed as complete individual words and chemically significant word segments. Words such as CHLOROBENZENE can be retrieved by either segment, e.g., S CHLORO or S BENZENE. Any term in the Basic Index can be restricted to a full word using the /FW suffix, e.g., S BENZENE/FW. Locants, such as 2,3, indicate the position of a chemical group within the structure and are searched as words, e.g., S 2(W)3.

³ Patent assignee/applicant names are searchable in the Basic Index with /CO and in the Additional Indexes as PA= and CO=.

⁴ Claims and specification text are provided in the original language for English, French, German, or Spanish patents. Records containing text in other languages contain abstracts only.

ADDITIONAL INDEXES

SEARCH PREFIX	DISPLAY CODE	FIELD NAME	INDEXING	SELECT EXAMPLES
AC=	AC	Application Country	Phrase	S AC=WO
AC=	PR	Priority Application Country ⁵	Phrase	S AC=ZA/PR
AD=	AD	Application Date	Phrase	S AD=20001204
AD=	PR	Priority Application Date ⁵	Phrase	S AD=19991215/PR
AM=	AD	Application Month	Phrase	S AM=200012
AM=	PR	Priority Application Month ⁵	Phrase	S AM=199912/PR
AN=	AN	Application Number ⁷	Phrase	S AN=WO 2000IB1789 S AN=WO IB0001789 S AN=ZA 997711 S AN=ZA 997711/PR
AN=	PR	Priority Application Number ^{5,6,7}	Phrase	
AN=	RE	Related Application Number	Phrase	
AU=	AU	Author/Inventor ^{1,8}	Word & Phrase	S AU=(DEKKER(N)ARIE) S AU=DEKKER ARIE CORNELIS
AV=	AV	Availability	Phrase	S AV=CLM
AY=	AY	Application Year	Phrase	S AY=2000
AY=	PR	Priority Application Year ⁵	Phrase	S AY=1999/PR
—	AZ	DIALOG Accession Number		
CN=	CN	Assignee/Inventor Country Code ⁹	Phrase	S CN=ZA
CO=	CO	Company (Assignee/Applicant) ^{1,3}	Phrase	S CO=POLYMER?
DS=	DS	Designated States	Phrase	S DS=GB
DT=	DT	Document Type	Phrase	S DT=PATENT
FC=	FC	Filing Country	Phrase	FC=IB

ADDITIONAL INDEXES (cont'd)

SEARCH PREFIX	DISPLAY CODE	FIELD NAME	INDEXING	SELECT EXAMPLES
GL=	GL	Assignee/Inventor Address	Word	S GL=MIDRAND S GL=(INDUSTRY(W)ROAD AND MIDRAND)
IA=	IC	International Patent Class (IPCR/8) Attributes ¹⁸	Phrase	S IA=I S IA=F(S)IC="A61K-0031/198"
IC=	IC	International Patent Class ^{10,11,17,18}	Phrase	S IC=H04R-0029/00 OR IC=H04R-029/00 S IC=H04R-0029 OR IC=H04R-029 S IC=H04R
ICA=	IC	Advanced International Patent Class ^{17,18}	Phrase	S ICA="H01L-0021/8234" S ICA=H01L-0021
—	IM	Image		
LA=	LA	Language of Publication	Phrase	S LA=ENGLISH
LD=	LD	Legal Status Date	Phrase	S LD=20010621
LF=	LF	Language of Filing ¹²	Phrase	S LF=DANISH
LR=	LR	Legal Representative ¹³	Word & Phrase	S LR=(WALLENSTEIN(1W)WAGNER) S LR=MORNEAULT MONIQUE?
LS=	LS	Legal Status	Phrase	S LS=A1 WITH INTERNATIONAL SEARCH?
LT=	LT	Legal Status Type	Phrase	S LT=PUBLICATION
LY=	—	Legal Status Year	Phrase	S LY=2001
PA=	PA	Patent Applicant/Assignee ^{1,3}	Word & Phrase	S PA=(RSC(W)MINING) S PA=RSC MINING?
PC=	PC	Patent Country	Phrase	S PC=WO S PC=WO A1 S PD=20010621
PD=	PD	Publication Date	Phrase	
—	PI	Patent Information ¹⁴		
PM=	PD	Patent Month	Phrase	S PM=200106
PN=	PN	Patent Number ⁷	Phrase	S PN=WO 200144621 S PN=WO 0144621
PR=	PT	Priority Data ⁵	Phrase	S PR=ZA 997711 S PR=19991215
PY=	PY	Publication Year	Phrase	S PY=2001
RT=	—	Record Type	Phrase	S RT=FULLTEXT
—	SR	Search Report		
UB=	UB	Update - Basic Patent ¹⁵	Phrase	S UB=9999
UD=	—	Update ¹⁵	Phrase	S UD=9999
UI=	UI	Update - Image	Phrase	S UI=9999
UL=	UL	Update - Legal Status	Phrase	S UL=9999
UT=	UT	Update - All Full Text ¹⁵	Phrase	S UT=9999
WD=	WD	Word Count ¹⁶	Numeric	S WD=3641 S WD<1000

⁵ Use the qualifier /PR to restrict a search to priority application data. Priority application numbers and dates can also be searched in the Priority Application field PR=.

⁶ U.S. priority application numbers may be searched in several ways: with two leading year digits for years prior to 2000 and four leading digits from 2000 on, e.g., S AN=US 96590668 or S AN=US 2000102574, with four trailing year digits, e.g., S AN=US 590668-1996, or the application number without any accompanying year digits, e.g. S AN=US 590668.

⁷ Patent and application numbers are formatted in standard DIALOG format for ease in MAPping to other patent databases. Numbers that contain leading year digits use 2 digits prior to 2000, and 4 year digits from 2000 forward. Use MAP PN or MAP AN to look for the corresponding legal status records in Inpadoc, File 345.

⁸ Inventor names may appear in direct order with the surname last or in inverted order with the surname first. For the most comprehensive retrieval, use the (N) operator, e.g. S AU=(JOHN(1N)EBERHARD).

⁹ Country (CN=) and Geographic Location (GL=) fields can be further restricted with suffixes. Use /PA to restrict to applicants and assignees or /AU to restrict to inventors. CN= can also be restricted to nationality using the suffix /NA.

¹⁰ Use /MA to restrict IPCs to the main IPC code to which a patent is assigned through December 2005, e.g. S IC=C25D-005/04/MA. For IPCR/8, use IA=F to identify the first/main class code.

¹¹ Some IPC class codes include a colon (:), which should be enclosed in quotes, e.g., S IC=" H01R-03:00", to ensure correct processing. These codes are never included as main IPC class numbers.

¹² Available from 2000 forward in most records.

¹³ The Legal Representative name can be searched as either word or phrase using LR=. The firm name and address can be searched as individual words only.

¹⁴ Patent information consists of patent number and date, application number and date and priority data.

¹⁵ Due to the fact that portions of this database update at different times, update codes UB= (WIPO Bibliographic data) and UT= (Thomson Scientific text) show the publication dates of the record. Generally, UT= will be one week behind UB=. UD= gives the week number of the WIPO update.

¹⁶ Word Count applies only to the text fields, i.e., specification and claims.

¹⁷ With the introduction of the Reformed International Patent Classification (IPCR/8) on January 1, 2006, the format of the IPC group has increased in length from 3 to 4 digits. For comprehensive retrieval, both forms of the classification should be searched, e.g., S IC=H04R-025/00 OR IC=H04R-0025/00 . Advanced level classification codes can be searched directly in the ICA= index. IPCR/8 Classification codes can be linked to their attributes using the S operator.

¹⁸ Each IPCR/8 classification code is also assigned a series of attributes. These include classification level (A - Advanced, C - Core, S - Subclass), value (I - Invention, N - Non-invention), position (F - First, L - Later), status (B - basic, R - Reclassified, V - Various, D - Deleted), version date, action date, source (H - Human, M - Machine, G - Generated), and assigning office. The classification attributes can be searched with the IA= prefix and can be linked to an IPCR/8 classification code (assigned after January 1, 2006) using the S operator and quotes around the classification code, e.g., S IA=F(S)IC="A61K-0031/198".

SPECIAL FEATURES

For command descriptions, enter HELP LIMIT, HELP SORT, HELP RANK, HELP MAP, HELP IDPAT online.

LIMIT	/ENG -- English Language /YYYY -- Publication Year	S S1/ENG S S4/2001
SORT	AN, AU, IC, PA, PD, PN, TI	SORT S6/ALL/IC
RANK	All phrase- and numeric-indexed fields in the Additional Indexes can be ranked. Additional RANK codes include: ANPR (Priority Application Number; ICMA (Main International Patent Class).	RANK AC
MAP	AN, ANPR, ANPRYY, ANYY, CO, IC, PA, PN	MAP PN T
IDPAT	Identify patent duplicates and display all or selected patent groups.	IDPAT IDPAT S1 SHORT

PREDEFINED FORMAT OPTIONS

NO.	DIALOGWEB FORMAT	RECORD CONTENT
1	--	DIALOG Accession Number
2	--	Bibliographic Citation, Patent and Application Data, International Patent Classification Codes, and Legal Status
3	--	Bibliographic Citation, Patent and Application Data
4	--	Full Record with Tagged Fields
5	Medium	Bibliographic Citation, Patent and Application Data, and Abstract(s)
6	Short	Title
7	--	Full Record with English Abstract only
8	--	Title, Word Count, Language of Publication, and International Patent Classification Codes
9	Long	Full Record
12	--	Format 2 plus Image
13	--	Format 3 plus Image
14	--	Format 4 plus Image
15	--	Format 5 plus Image
17	--	Format 7 plus Image
19	Full	Full Record plus Image
26	--	Title, Language, Word Count and Publication Year
K	--	KWIC (Key Word In Context) displays a window of text; may be used alone or with other formats

OTHER OUTPUT OPTIONS

For an explanation, enter HELP TYPE, HELP UDF, HELP TAG online.

USER DEFINED FORMATS	Display codes listed in the Search Options tables can be used to customize output	TYPE S4/TI,PA,PN/1-5 PRINT S5/TI,PN,TX/ALL
TAG	Output can be displayed with tags identifying each display field	TYPE S4/6,PA/ALL TAG
DIRECT RECORD ACCESS	If the accession number of a specific record is known, it can be used to display the record directly.	TYPE 00085603/9 PRINT 00095905/9

FOR ONLINE HELP:

See HELP FIELDS 349 for searchable fields; HELP FORMAT 349 for output formats; HELP LIMIT 349 for limits; HELP RATES 349 for cost information; HELP SORT 349 for sorts.